

APPLICATION NOTE

**CFL 13W demo PCB with
UBA2021 for
integrated lamp-ballast designs
AN98091**

Abstract

A description is given of a 13W electronic CFL ballast (SMD demo board PR38922 and leaded demo board PR39001), which is able to drive a standard Philips PLC 13W and similar lamps. The ballast is based on a Voltage Fed Half Bridge Inverter topology. It is designed for a nominal mains input voltage of $230V_{rms} \pm 15\%$. The Half Bridge switching devices (discrete Power MOSFET PHU2N60 or the rugged PHU2N50) are driven and controlled by the UBA2021 high voltage IC. Therefore this UBA2021 IC contains a driver circuit (with integrated high-side drive and bootstrap circuit); an oscillator; and a control & timer circuit for starting up, preheating, ignition, lamp burning and capacitive mode protection. The circuit is intended for integrated ballast-lamp designs.

© Philips Electronics N.V. 1998

All rights are reserved. Reproduction in whole or in part is prohibited without the prior written consent of the copyright owner.

The information presented in this document does not form part of any quotation or contract, is believed to be accurate and reliable and may be changed without notice. No liability will be accepted by the publisher for any consequence of its use. Publication thereof does not convey nor imply any license under patent- or other industrial or intellectual property rights.

APPLICATION NOTE

**CFL 13W demo PCB with
UBA2021 for
integrated lamp-ballast designs
AN98091**

Author(s):

E. Derckx

**Philips Semiconductors Systems Laboratory Eindhoven,
The Netherlands**

Approved by:

B. Verhoeven

H. Simons

Keywords

CFL Ballast
UBA2021
Compact
Half Bridge
Driver circuit

Number of pages: 17
Version 2, date: 19 October 1998

Summary

In the underlying report a description is given of an electronic CFL 13W ballast. The ballast is a Voltage Fed Half Bridge, which has been optimised to drive a standard Philips PLC 13W burner and similar lamps. The circuit has been designed for a nominal mains-input voltage of $230V_{rms} \pm 15\%$, 50-60Hz. Furthermore the circuit is intended for integrated ballast-lamp designs, so no protection against lamp removal has been implemented.

One of the key components is the UBA2021 IC. This is a high voltage IC intended to drive and control a Compact Fluorescent Lamp (CFL). It consists out of a driver circuit for an external half bridge (high-side driver and bootstrap circuit included); an oscillator; and a timing & control circuit for starting up, preheating, ignition, lamp burning and capacitive mode protection.

The operating frequency of the circuit is approximately 43 kHz. This frequency is determined by the UBA2021 IC and its timing & control components.

CONTENTS

1. INTRODUCTION.....7

2. CIRCUIT & SYSTEM DESCRIPTION 8

2.1 Block diagram 8

2.2 Start up phase 8

2.3 Preheat phase 9

2.4 Ignition phase 9

2.5 Burn phase 10

2.6 Capacitive mode protection 10

3.CFL 13W DEMO APPLICATIONS 12

3.1 Schematic diagram 12

3.2 SMD version: demo board PR38922 12

3.2.1 PR38922 (SMD version)..... 12

3.2.2 Parts list of PR38922 (SMD version)..... 13

3.3 Ledged version: demo board PR39001 14

3.3.1 PR39001 (leaded version)..... 14

3.3.2 Parts list of PR39001 (leaded version) 14

4. PERFORMANCE 16

4.1 Oscillograms 16

4.2 RFI-measurement..... 17

1. INTRODUCTION

A small and low cost electronic CFL ballast has been designed, which is able to drive a 13W Philips PLC lamp or similar 13W Compact Fluorescent Lamps (CFL). The circuit is intended for integrated ballast-lamp designs. Therefore no additional protection against lamp removal is required.

A Voltage Fed Half Bridge inverter has been chosen as lamp driver circuit. The inverter has been designed for a nominal input voltage of $230V_{rms} \pm 15\%$, 50-60Hz. The key component in this circuit is the UBA2021 Integrated Circuit. This UBA2021 is a high voltage driver IC, which provides all the necessary functions for a correct preheat, ignition and burn-state operation of the lamp. Besides these control function the UBA2021 provides the level-shift and drive function (high-side driver and bootstrap circuit included) for the two discrete power MOSFETS PHU2N60.

The key issues for this design are: compact, low cost and low component count. The UBA2021 IC has a few peripheral components. Only a minimum of components are required for the optimal balance between maximum design flexibility and low component count. Furthermore, all components are of compact size.

For a reliable system operation and a long lamp life, the fluorescent lamp is preheated first, after switch on. This preheat is controlled by the UBA2021 IC. The electrode currents and voltages meet the requirements to obtain a proper electrode-emitter temperature. This results in a smooth ignition of the lamp at a much lower ignition voltage, with less component- and/or electrical stress.

In the burn phase, the operation frequency is approximately 43kHz, so no interference with infra red communication systems (32-36kHz) will occur. Furthermore this frequency is kept below 50kHz (third harmonic < 150kHz), which meets a better RFI performance. During steady state operation, the frequency is determined by a feed forward control. The result is a constant level of light output over a large mains voltage range (approximately 200..250V).

The 13W CFL ballast with UBA2021 is available on two versions of printed circuit boards. Printed circuit board PR38922 is a miniaturised version with SMD components (referred to as SMD-version). Printed circuit board PR39001 consists out of leaded components only (referred to as leaded-version). Both PCBs contain the same electrical circuit. Their board designs (PCB layout) meet the requirements for a good EMC performance.

2. CIRCUIT & SYSTEM DESCRIPTION

2.1 Block diagram

The CFL ballast has been designed for a mains voltage range of $230V_{rms} \pm 15\%$, 50/60Hz. Basically, the circuit consists out of two sections: AC bridge rectifier and the half bridge inverter. Figure 1. shows the block diagram of the circuit; the complete schematic diagram is given in paragraph 3.1.

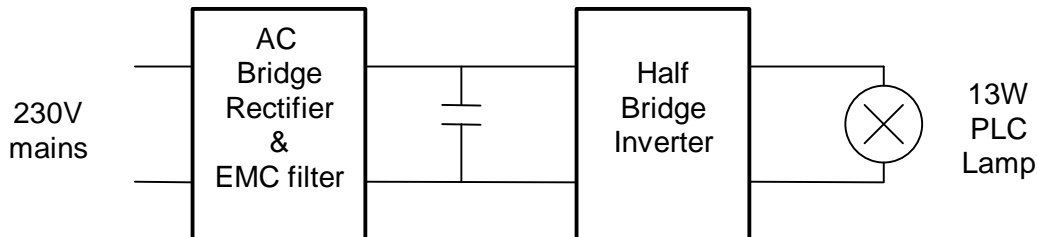

Figure 1. Block diagram CFL ballast

The AC mains voltage is rectified by four bridge rectifying diodes and the DC supply voltage for the half bridge inverter is smoothed by a buffer capacitor. An EMC-filter is used to minimise the disturbance towards the mains. The half bridge inverter is a voltage fed type and has been designed to operate a 13W PLC lamp or similar lamps.

The voltage fed inverter belongs to a group of high frequency resonant inverters, which are very attractive to drive lamp circuits. They can achieve a high efficiency, due to the zero-voltage switching principle. This reduces the switching losses of the two power MOSFETS PHU2N60 to a minimum, so the power loss is MOSFET ON-loss. Therefore the steady state operation (thermal resistance & ON-loss) determines the choice of MOSFET type (by $R_{ds(on)}$). Mention that during ignition and preheat, the total MOSFET current has to be below the specified maximum rating! All together the PHU2N60 ($R_{ds(on)} < 6\Omega$, $V_{ds-max} = 600V$) suites best in this application.

NOTE: a further increased thermal management will be achieved, when rugged types PHU2N50 will be used. The PHU2N50 power MOSFETS have a lower R_{ds-on} and high repetitive avalanche energy ratings ($V_{ds-max} = 520V$). These devices will become available in March 1999.

In the next paragraphs, a more detailed circuit and system description will be given. It is subdivided into five sections namely the start up, preheat, ignition, burn phase and protection.

2.2 Start up phase

After switch on of the system, the rectified mains voltage is applied to the buffer capacitor C2. This capacitor smoothes the ripple voltage, caused by the (doubled) mains frequency. The result is a high DC voltage V_{hv} , which is an input for the half bridge inverter (power components: Q1, Q2, L2, C5, the lamp, C3 and C4). The inductor L1 is used as an EMI-coil. This L1 will minimise disturbances towards the mains. In paragraph 4.2, a measurement of the conducted EMI is given.

During the start up phase, the low voltage supply capacitor C8 is charged, out of the high DC voltage, via the resistors R3, R5 and the UBA2021 IC (start up supply path). As soon as the supply voltage V_s over C8 reaches 5.5 Volt, the UBA2021 resets. After this initial reset MOSFET Q2 is set conductive and MOSFET Q1 is non-conductive. This allows the bootstrap capacitor C9 to get charged as well by the UBA2021 IC (via an internal bootstrap circuit). The supply voltage V_s further increases and the circuit starts oscillating at $V_s > 12$ Volt. The system is now in the preheat phase.

2.3 Preheat phase

The MOSFETS Q1 and Q2 are brought in conduction alternately. This introduces a square-wave voltage V_{hb} across the half bridge midpoint, that is between zero and V_{hv} . The start-frequency of this voltage V_{hb} is approximately 85 kHz. Under these conditions the circuit formed by C12, C7, D6 and D5 is able to take over the low voltage supply function from the start up supply path. C12 and C7 are also used as a snubber-circuit for the half bridge switches.

During the whole preheat phase, the half bridge frequency is well above the resonance frequency of L2 and C5, so the voltage across C5 is low enough (< 250 Vrms) to keep the lamp non-ignited. The combination of L2 and C5 is determined by the required lamp current and operation frequency in the **burn phase**. The preheat phase gives an additional requirement for the limit of the minimum value of C5 at given L2, determined by the non-ignition voltage of the lamp (< 250 Vrms).

At start frequency, a small AC current starts floating from the half bridge midpoint, through L2, C5 and the lamp electrodes. The frequency now gradually decreases and the AC current increases. The slope of decrease in frequency is determined by the value of capacitor C6. The decrease stops (approximately 1.5 ms after switch on) when a defined value of the AC current through R4 is reached, which is a reference for the AC current through the lamp electrodes. The UBA2021 now controls the AC current through the lamp electrodes, by measuring the voltage drop across R4. This control point is called preheat operation point. In paragraph 4.1, an oscillogram of this controlled preheat is given (see figures 5. and 6.).

For a time period of approximately 300ms (preheat time), defined by capacitor C10 and R2, the system stays in the preheat operation point, where lamp electrode current is controlled. This allows both the lamp electrodes to heat up in a defined, optimal way. The electrodes-emitters are powered and large quantities of electrons are emitted into the lamp. Ignition of the lamp now can take place at a much lower ignition voltage, at less electrical stress of the circuit and less stress to the lamp. To obtain a long life time of the lamp, this defined electrode preheat, followed by a smooth ignition is very important!

The ignition phase is described in the next paragraph.

2.4 Ignition phase

After the expiration of the preheat time, the UBA2021 further decreases the switching frequency of the half bridge.

The load is still inductive so the lamp voltage (AC voltage across C5) goes up as the frequency goes down. Typically the lamp ignition voltage can exceed 460 Vrms, which even guarantees lamp ignition at low temperatures. The combination of values for lamp coil L2 and lamp capacitor C5 has been chosen in such a way that the voltage across the lamp can reach these high levels. The minimum required ignition voltage will determine a limit for the maximum value of C5 at a given L2.

During actual ignition, the operation frequency of the half bridge is a few kHz above the resonance frequency of series circuit formed by L2, C5 and the electrodes. After ignition of the lamp, transition to the burn phase takes place.

The operating frequency normally decreases to the bottom frequency F_{bottom} . This will be done in one continuous frequency sweep down from the preheat phase. The UBA2021 IC can make the transition to burn phase in two ways, by:

- Reaching the F_{bottom} ,
- Reaching the ignition-time.

F_{bottom} is approximately 33 kHz and set by R2 and C11. The ignition time is approximately 280ms (defined as 15/16 part of the preheat time, determined by R2 and C10).

2.5 Burn phase

In the burn phase the circuit normally would like to drop down to F_{bottom} (=33kHz). However a feed forward control becomes active after the ignition phase. The principle of feed forward control will be explained within a few paragraphs. For now it is important to know that the operation frequency is kept by this feed forward control at approximately 43 kHz at a nominal input of 230Vrms. The half bridge now supplies a square-wave voltage, with amplitude equal to half the rectified mains voltage and frequency equal to 43 kHz, to the lamp circuit. Basically the lamp can be seen as a resistive load in parallel to lamp capacitor C5.

The half bridge inverter, in combination with the lamp circuit formed by L2, C5 and the lamp, has been designed for a nominal mains voltage of 230Vrms. The steady state operating point of a 13W PLC lamp is approximately: a lamp voltage of 75 V, a lamp current of 170mA and a lamp power of 13W. These values have to be met at a mains voltage of 230Vrms, in order to obtain a long lamp life.

It can be calculated that for the actual values of L2, C5 and a 13W PLC lamp, the total circuit delivers the desired lamp power (at the desired steady-state lamp voltage, lamp current and nominal mains input voltage). However also other L2/C5-combinations are possible. Parameters like the preheat operation point, the minimum required ignition voltage and component tolerances determine, which combination suites best. The result is that an inductance of $L2 = 3.1\text{mH}$ as ballast coil and lamp capacitor $C5 = 3.9\text{nF}$ give the best over all performance.

Above a defined voltage level, the switching frequency of the half bridge also depends on the amplitude of the mains voltage. In the burn phase, the current through R3 and R5 is monitored by the UBA2021 IC. Indirectly this current is proportional to the amplitude of the applied mains voltage. The UBA2021 IC uses the variation of mains voltage-amplitude information to increase/decrease the operating frequency. The effect is that the lamp power stays more or less the same over an input mains voltage range from 200 up to 250 Volt. This principle is called the feedforward control.

Normally an increase of the mains voltage (above 230 Vrms) , would result in an increase of the lamp power, because the half bridge inverter is a Voltage Fed type. This increased lamp power could further result in high temperatures of/in the lamp. Eventually this will cause an early failure of the lamp. The feed forward control of the UBA2021 IC prevents the lamp and circuit against the increase of lamp power.

In order to prevent feedforward control on the ripple (100/120Hz) of V_{hv} , the UBA2021 IC uses C10 to filter out this ripple.

2.6 Capacitive mode protection

To protect the power circuit against excessive electrical stress, a capacitive mode protection has been implemented in the UBA2021 IC. This protection will become active during the ignition and burn phase. Therefore the UBA2021 IC checks the zero-voltage switching condition each half bridge switching cycle. This is done by monitoring the voltage across R4. If this voltage is below 20mV typical at the time of turn on of Q2, capacitive mode operation is assumed.

APPLICATION NOTE

Application Note

As long as this capacitive mode is detected, the UBA2021 IC increases the switching frequency. This measure will limit the half bridge output-current to a maximum value. If no capacitive mode is detected, the frequency drops down again to the feedforward frequency (43 kHz).

3. CFL 13W DEMO APPLICATIONS

Two versions of the 13W CFL application were made. Demo board PR38922 is a SMD version; PR39001 is a leaded version. Both demo boards are based on the same schematic diagram.

3.1 Schematic diagram

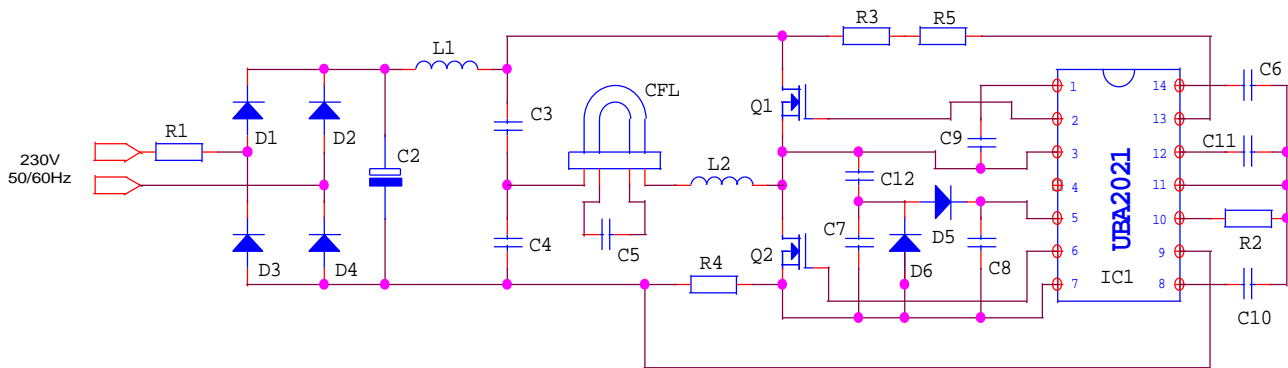

Figure 2. Schematic diagram

3.2 SMD version: demo board PR38922

3.2.1 PR38922 (SMD version)

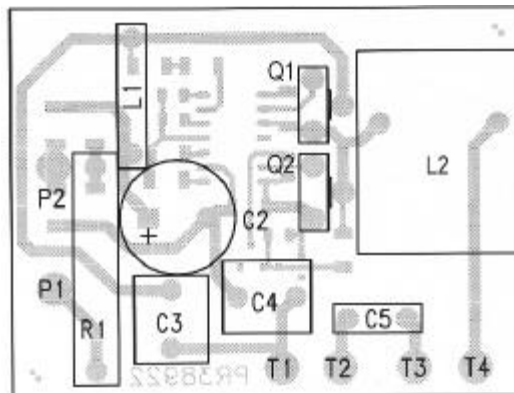

Figure 3. PR38922 (component side)*

*Actual size of PCB PR38922 is 33mm x 44mm.

3.2.2 Parts list of PR38922 (SMD version)

Component	Value / type	12NC – Philips order number
R1	47Ω - PR02	2322 194 13479
R2	27kΩ - RC02G	2322 723 61273
R3, R5	200kΩ - RC02G	2322 723 61204
R4	1.3Ω - RC02G	2322 723 61138
D1, D2, D3, D4	BYD17M - SOD87	9338 122 70115
D5, D6	BAS16 - SOT23	9334 606 20212
C2	3.3μF/400V - RLH151	2222 151 56338
C3, C4	100nF/250V - MKP465	2222 465 90001
C5	3.9nF/400V - MKP370	2222 370 90149
C6	47nF/50V - X7R 0805	2222 590 16636
C7	680pF/50V - NP0 0805	2222 861 12681
C8	100nF/50V - X7R 0805	2222 580 16741
C9, C10	100nF/50V - X7R 1206	2222 581 16641
C11	150pF/50V - NP0 0805	2222 861 12151
C12	470pF/500V - NP0 1206	2222 971 11545
L1	820μH - 140mA	TAIYO UDEN
L2	3.1mH - CE167v	8228 001 32541
Q1, Q2	PHU2N60E / PHU2N50E	-
IC1	UBA2021T - S014	9352 112 50112/118

Table 1. PR38922 parts list

3.3 Leded version: demo board PR39001

3.3.1 PR39001 (leaded version)

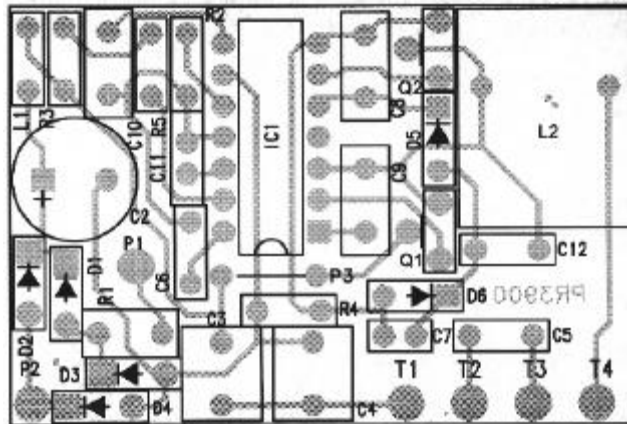

Figure 4. PR39001

*Actual size of PCB PR39001 is 34mm x 50 mm.

3.3.2 Parts list of PR39001 (leaded version)

Component	Value / type	12NC – Philips order number
R1	47Ω - PR02	2322 194 13479
R2	27kΩ - SFR25	2322 181 43273
R3, R5	200kΩ - SFR25	2322 181 43204
R4	1.3Ω - SFR25	2322 181 43138
D1, D2, D3, D4	BYD12M	9340 552 67143
D5, D6	1N4531	9332 039 80113
C2	3.3μF/400V - RLH151	2222 151 56338
C3, C4	100nF/250V - MKP465	2222 465 90001
C5	3.9nF/400V - MKP370	2222 370 90149
C6	47nF/100V - MKT370	2222 370 21473
C7	680pF/100V - C630	2222 630 02681
C8, C9, C10	100nF/63V - MKT370	2222 370 75104
C11	150pF/100V - C631	2222 631 34151

APPLICATION NOTE**Application Note**

C12	470pF/500V - C655	2222 655 03471
L1	820 μ H - 140mA	TAIYO UDEN
L2	3.1mH - CE167v	8228 001 32541
Q1, Q2	PHU2N60E / PHU2N50E	-
IC1	UBA2021 - DIP14	-

Table 2. PR39001 parts list

4. PERFORMANCE

4.1 Oscillograms

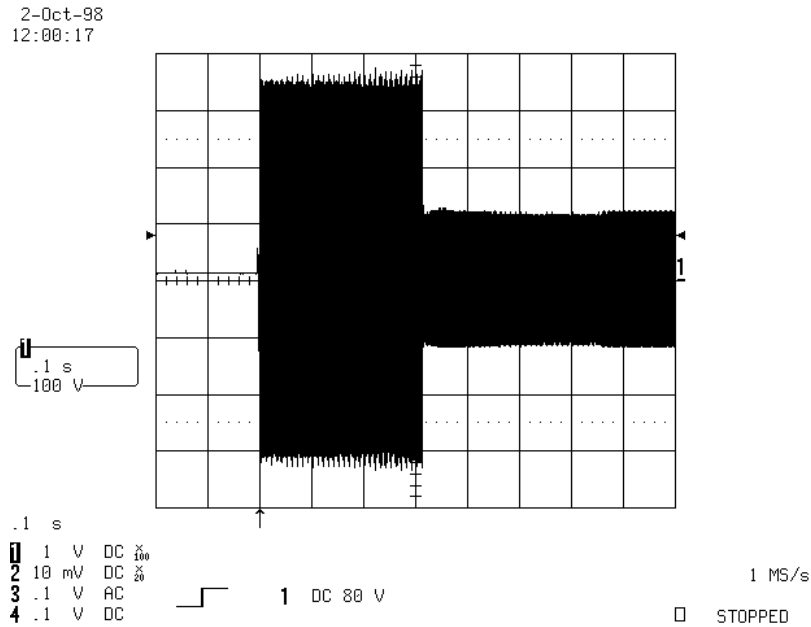

Figure 5. Preheat (± 300 ms), ignition (not visible) & burn phase
(CH1. lamp voltage: 100V/div; time base: 100ms/div)

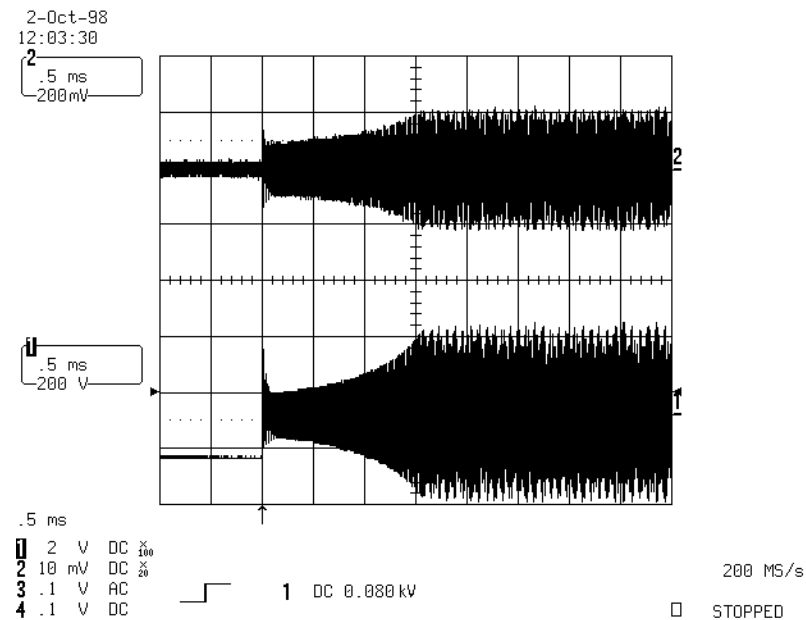

Figure 6. From start-up to controlled preheat within 1.5ms
(CH1. lamp voltage: 200V/div & CH2. electrode current: 500mA/div; time base: 0.5ms/div)

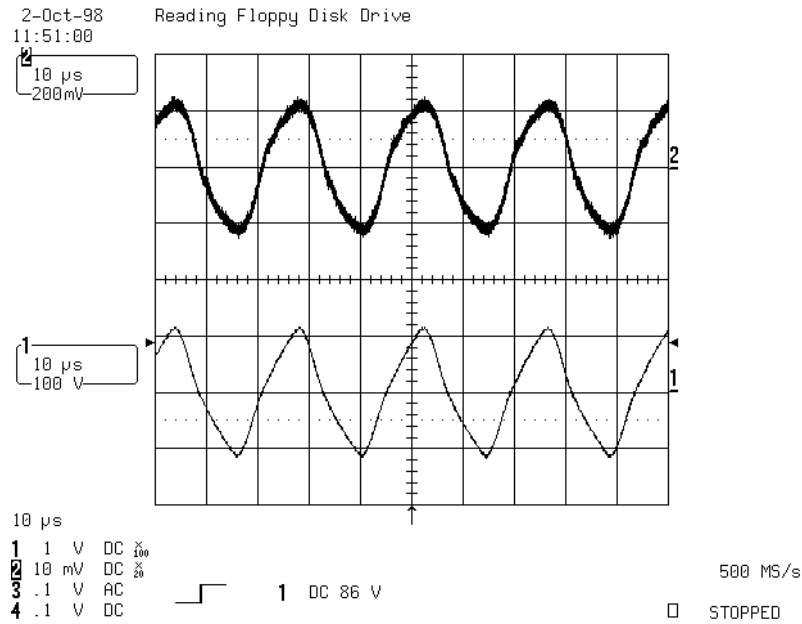

Figure 7. Burn phase: lamp voltage 75V & lamp current 170mA
 (CH1. lamp voltage: 100V/div & CH2. lamp current: 200mA/div; time base: 10µs/div)

4.2 RFI-measurement

The mains terminal disturbance (conducted EMI) of the 13W CFL circuit was measured according procedure 96EMC3005.1 "Conducted emission with an Artificial Mains Network. All measured values are average voltages in dBµV. As a comparison the CISPR15 average limit is given too.

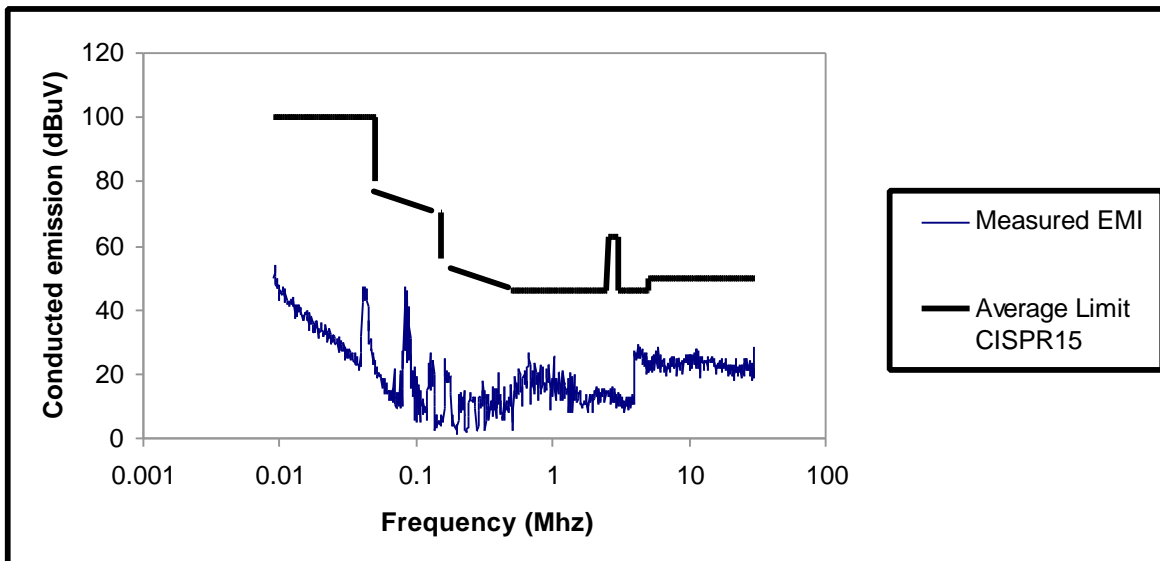

Figure 8. Conducted EMI